

FLATMASTER - POSITIVE INPUT VENTILATION (PIV)

LOW COST VENTILATION FOR PROPERTIES WITH NO LOFT SPACE,
THAT SAVES ENERGY AND PREVENTS CONDENSATION.



BENEFITS

EXTREMELY LOW POWER CONSUMPTION

As low as 3 Watts.

EASY INSTALLATION & VERY LOW MAINTENANCE REQUIREMENT

Filter clean or replacement typically every 18 months.

SIGNIFICANTLY IMPROVES INDOOR AIR QUALITY

Using positive input ventilation removes indoor air pollutants such as carbon monoxide and keeps out traffic fumes, pollen and outdoor pollutants.

COMPLIES WITH THE BUILDING REGULATION VENTILATION REQUIREMENTS

Meets Part F&L England and Wales and contributes towards 'conservation of fuel and power'. (Please refer to BBA Certificate).

RADON GAS CONTROL

Helps reduce and maintain radon gas levels.

CREATES A HEALTHIER LIVING ENVIRONMENT

High efficiency filters removes up to 95% dust particles.

FIT & FORGET OPERATION

Fully automatic when airflow set on installation.

OPTIONAL HEATER FACILITY

To provide additional heat to the incoming air if required i.e. during very cold weather

HOUR RUN MONITOR AVAILABLE

To record the units operational time

WARRANTY

5 year warranty for peace of mind.



TYPICAL INSTALLATION



Quick maintenance with easily cleaned filter.



Louvered vent.

FLATMASTER

Typical installations show unit with top discharge.

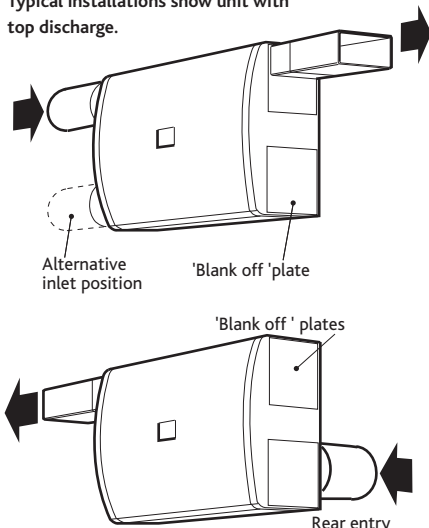

The unit is designed to take fresh air from outside, clean the air, warm it (if fitted with heater) and discharge it into the central hallway via a system of ducting supplied by the installer. The dwelling internal air discharge grille is usually installed at high level in a central location within the hallway, although discharging the air down the length of the hallway (away from the front door) should also prove acceptable. Unit performance may be

enhanced if an existing heat source can warm the discharged air eg. by locating the discharge grille above a radiator.

FLATMASTER- HEATER KIT OPTION

Heater kit option - contains a blank insert with a cut out for the switch. This blank can be fitted into any appropriate opening but it is important that the switch is fitted so that the terminals are at the bottom.

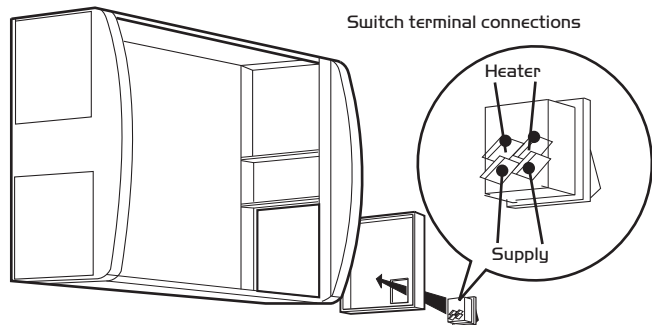

Note: Switch must be inserted into cut out in the blanking plate with the terminals to the bottom as shown.

DIMENSIONS (MM) & WEIGHT FLATMASTER UNIT

Weight: 6kg

100mm dia. or 121 x 60mm interchangeable spigots supplied with unit.

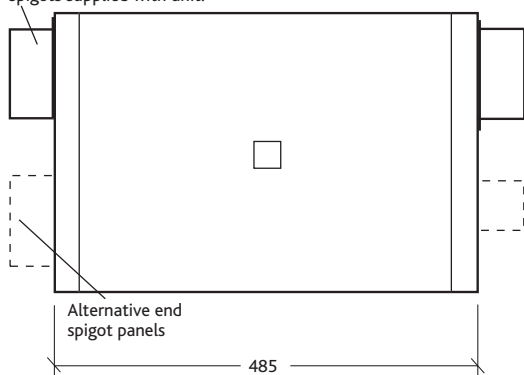

Alternative end spigot panels

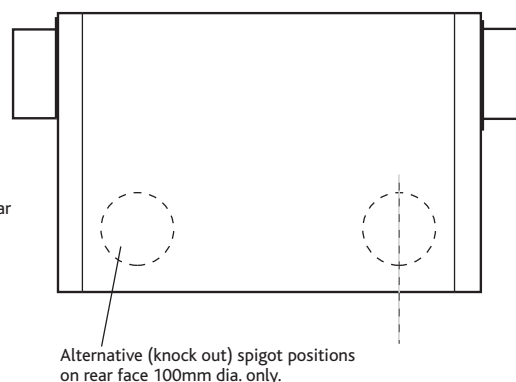
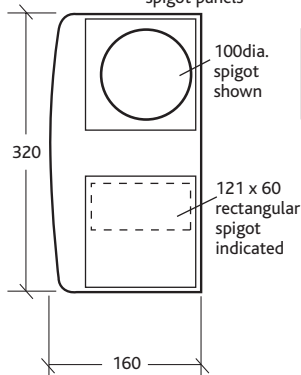

WIRING

Please note the electrical connections to the unit should be carried out by a qualified electrician.

With the PCB cover removed pull the PCB forward to gain access to earth post behind. Connect Earth cable to Earth Post next to the grommet hole. (If the heater option is required the wiring should be connected to the appropriate terminal on the PCB). Slide PCB into slot and connect the mains supply L and N to the terminal block.

Electrical details:-

Supply - 230V 1 phase 50Hz

Power Consumption
(without heater option)

Speed 1 - 5 Watts

Speed 2 - 8 Watts

Speed 3 - 13 Watts

Optional Heater - 300 Watts.

The unit should be wired in accordance with current IEE regulations.

Heater option wiring for general application.

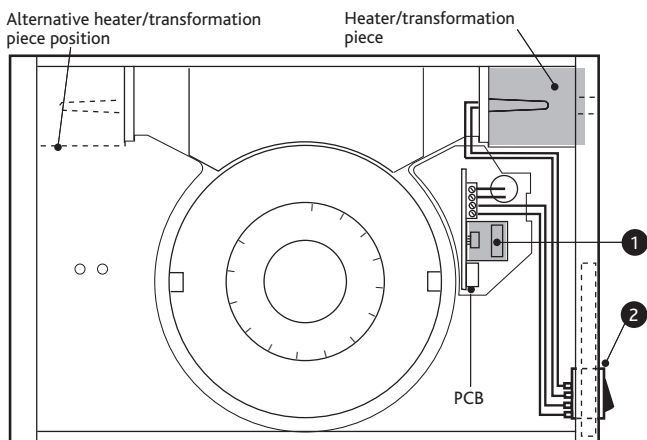

1 Optional plug-in 'hour run monitor' (records number of hours run) order code: FLAT-HRM.

2 Neon switch plate used for all general applications (except bathroom) see below. The electrical supply for the heater is taken from the PCB terminal block and connected the two lower tags on the neon switch. The upper pair of tags on the neon accept the heater leads.

CONSULTANTS SPECIFICATION

FAN DESCRIPTION

The attractively designed unit casing shall be manufactured from easy to clean flame retardant V0 rated ABS polymer and thermally insulated pre-coated mild steel. A washable flame retardant filter of G3 grade (with 1 - 2 year typical maintenance period) shall be fitted which may be accessed via the easily removable front cover.

The unit shall incorporate an injection moulded radial bladed centrifugal impeller. The impeller shall be driven by a high efficiency, reversible brushless DC motor fitted with sealed, self lubricating bearings and locked rotor protection.

The unit shall have a maximum power consumption of 0.45w/l/s of airflow. The unit shall be highly adaptable for ease of installation allowing circular or rectangular duct connections and for air entry from the side or rear of the case at high or low level.

A selection of spigots enabling connection to 100mm circular or 121x60mm rectangular distribution ductwork without the use of transformation sections shall be provided. The unit shall provide 3 volume control settings. Ducting and grilles shall be supplied separately.

The unit shall be suitable for the incorporation of an optional electric air-tempering heater as a plug in kit (Code: FLAT-HEATER). The unit shall be suitable for the incorporation of an optional plug in internal monitor which shall record the units operational time (Code: FLAT-HRM).

The unit shall be offered with a 5 year warranty.